

Living Well with Dementia – the National Dementia Strategy Action plan for Devon

Document Control

<i>Revision Date</i>	<i>Summary of changes</i>	<i>Version Issued</i>	<i>Issued to</i>
19/06/09	Second Draft to incorporate governance structure and further detail on delivery strategy	0.2	JR
29/06/09	Third draft following review with Jenny Richards and Laura Reeves regarding definition of measurements	0.3	JR, AG (for input OB10)
08/07/09	Forth draft following review by Jenny Richards and further consultation with stakeholders	0.4	JR
23/07/09	Fifth draft following workshop to review measures with Ruth Baker, Laura Reeves, Jenny Richards	0.5	JR
28/07/09	Sixth draft following review with Jenny Richards	0.6	JR
11/08/09	Seventh draft following stakeholder feedback	0.7	Adult Ops meeting
20/11/09	Eighth draft following SW dementia review and OSC feedback	0.8	SHA/SW review team OSC ACS/PCT/provider orgs/DDPG

Background

The Dementia UK report identified that one in 20 people over 65, and one in five over 80, are affected by dementia. In Devon, estimates indicate that more than 12,000 people will have dementia rising to more than 17,000 in 2021.

Devon's strategic objective in relation to dementia is to narrow the gap between the recorded and the currently estimated prevalence of dementia by at least 25% in the next 5 years.

Our action headlines:

- Improve awareness of dementia, both among the general public and among health and social care professionals through information and education
- Ensure arrangements are in place to diagnose the condition as early as possible to allow for earlier intervention and delivery of high quality care and support for people with dementia and their carers
- Continue to make progress against the dementia action plan through joint commissioning arrangements for people with dementia
- Stimulate market development across the range and type of care and housing support services available for people with dementia and their carers

The National Dementia Strategy sets out 17 objectives under the following headings:

- Raising awareness and understanding
- Early diagnosis and support
- Living well with dementia
- Delivering the National dementia Strategy

The following actions plan addresses each of these objectives and gives details as to how they will be met.

Approach

The National Dementia Strategy (NDS) sets out 17 key objectives. These objectives will be met using a programme/ project approach and this document shall be the main source of defining and tracking progress. However the following documents are also relevant:

- “*Joint Commissioning Strategy for people with dementia in Devon*”
- “[*Living Well with dementia: A national dementia strategy*](#)”
- “[*Joint commissioning framework for dementia*](#)”

A Programme Board will convene with, in summary, responsibility to ensure:

- That the objectives are achieved
- That progress towards achieving the objectives is monitored
- There are effective measures in place to ensure that the objectives have been achieved

A full Terms of Reference for this Board is documented separately.

The Programme Board will report into the Putting People First Programme Board, who in turn report into both the ACS SMG and PCT SMT.

Two independent bodies, The Devon Dementia Partnership Group and the Devon Primary Care Trust Professional Expert Group (DPT PEG) will act as reference groups for the Programme Board with, in summary, responsibility to:

- Provide independent point of reference and challenge
- Undertake specific work packages to achieve the objectives as defined by, and agreed with the Programme Board

Again, a full terms of reference for these groups is documented separately.

The role of the Programme/ Project Manager will be fulfilled by the Joint Strategic Commissioning Manager (OPMH). Assistance will be given with this role by way of Programme/ Project Assurance.

It should also be noted that many of the objectives have strong links into other national strategies and in many cases, programmes aimed specifically at these are being constructed or are already underway. It is important to recognise this when undertaking this programme of work to ensure that any activities are in synergy with the other programmes. Therefore realisation of these objectives will be achieved in 2 fundamental ways.

- Linking in with other relevant work streams and programmes to ensure that the objectives within this strategy are met within the scope of that groups work
- Where there is no relevant work stream or programme in existence, creation of a new projects/ work streams to deliver that objective

Achievement of the objectives and outcomes within the strategy will occur over a 1 to 5 year period and in some cases measurement will only happen beyond that timeframe. It will be within the remit of the Programme Board to establish appropriate governance arrangements and monitoring mechanisms for the “whole life” of the strategy.

It should also be noted that Devon Partnership Trust as the main provider of specialist OPMH services is undergoing its own programme of redesign which is being managed through a DPT Task Group, regularly reporting to Commissioners and in line with the overall strategic direction. This is also linked to the Transforming Community Services programme led through PCT Commissioning arrangements.

Standard Risk and Issue Management protocols will be adopted and a Risk Register and Issue Log will be created, updated and monitored by the Programme Board.

Please refer to the attached Dementia Strategy Performance Framework for detailed measures against each objective.

NDS Project Board Governance

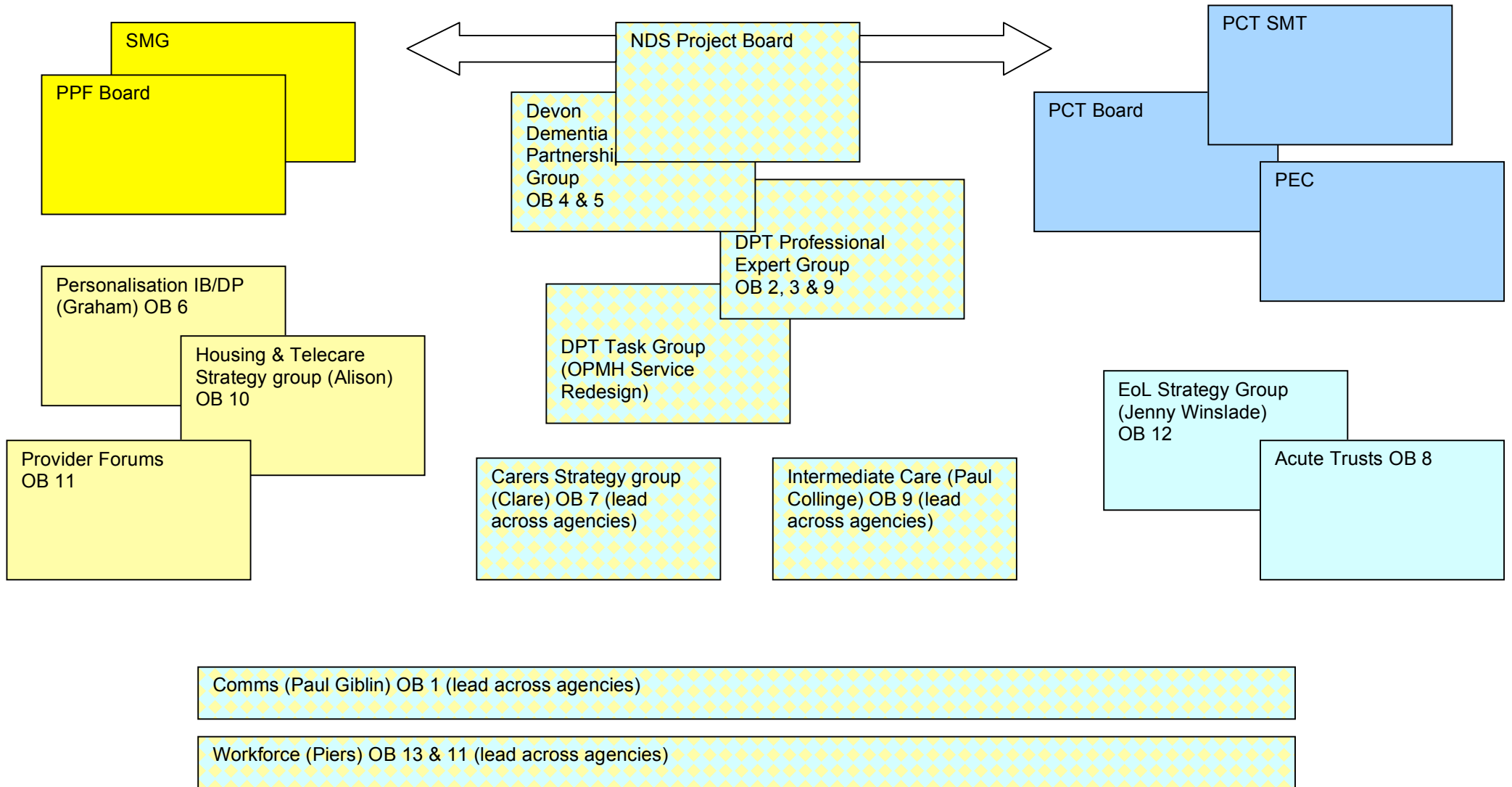

Governance Summary

This section illustrates the link between Programme Board members and objectives within the NDS. The purpose being to establish clear governance of each objective.

	Objective	Responsible Officer	Project Manager/ Lead Officer
1	Improving public and professional awareness and understanding of dementia.	Jenny Richards	Jenny Richards/Paul Giblin
2	Good-quality early diagnosis and intervention for all.	Dr David Somerfield	Ruth Baker
3	Good-quality information for those with diagnosed dementia and their carers.	Dr David Somerfield	Ruth Baker
4	Enabling easy access to care, support and advice following diagnosis.	Jenny Richards	Jenny Richards
5	Development of structured peer support and learning networks	Jenny Richards	Jenny Richards/DDPG/AS/DACVS
6	Improved community personal support services.	Jennie Stephens	Graham Varley/Paul Collinge
7	Implementing the Carers' Strategy for people with dementia.	Jennie Stephens	Clare Cotter
8	Improved quality of care for people with dementia in general hospitals	TBA- Representative from Acute Trust (RD&E) TBA- Representative from ND Healthcare Trust	TBA- Representative from Acute Trust (RD&E) TBA- Representative from ND Healthcare Trust
9	Improved intermediate care for people with dementia.	Jennie Stephens	Paul Collinge
10	Considering the potential for housing support, housing related services and telecare to support people with dementia and their carers.	Jennie Stephens	Alison Golby
11	Living well with dementia in care homes	Jenny Richards/ TBA GP Clinical Lead	Jenny Richards/ TBA GP Clinical Lead
12	Improved end of life care for people with dementia	Jenny Winslade	Lorna Potter
13	An informed and effective workforce for people with dementia	Piers Tetley TBA- Representative from Acute Trust (RD&E) TBA- Representative from ND Healthcare Trust	Katy Kerley TBA- Representative from Acute Trust (RD&E) TBA- Representative from ND Healthcare Trust
14	A joint commissioning strategy for dementia.	Jenny Richards	Jenny Richards
15	Improved assessment and regulation of health and care services and of how systems are working for people with dementia and their carers.	None (Objective is a CQC requirement)	None (Objective is a CQC responsibility)
16	A clear picture of research evidence and needs.	None (Objective is DH responsibility)	None (Objective is DH responsibility)
17	Effective national and regional support for implementation of the Strategy.	None (Objective is DH responsibility)	None (Objective is DH responsibility)

DH Implementation timescales

Figure 1: Implementing the Strategy: 2009 – 2014



Programme Plan for Devon

This section illustrates the high-level plan for delivery of the objectives. Detailed plans for related programmes and individual working packages are contained within their respective documentation, along with supporting evidence.

Objective	2009-10	2010-11	2011-12	2012-13	2013-14
1. Improving public and professional awareness and understanding of dementia.	Gearing up	Coming on stream	Full Implementation		
2. Good-quality early diagnosis and intervention for all.	Gearing up	Coming on stream	Full Implementation		
3. Good-quality information for those with diagnosed dementia and their carers.	Gearing up	Coming on stream	Full Implementation		
4. Enabling easy access to care, support and advice following diagnosis.	Gearing up		Coming on stream	Full Implementation	
5. Development of structured peer support and learning networks	Gearing up	Coming on stream	Full Implementation		
6. Improved community personal support services.	Gearing up	Coming on stream		Full implementation	
7. Implementing the Carers' Strategy for people with dementia.	Gearing up	Coming on stream		Full implementation	
8. Improved quality of care for people with dementia in general hospitals.	Gearing up		Coming on stream	Full Implementation	
9. Improved intermediate care for people with dementia.	Gearing up	Coming on stream		Full Implementation	

Objective	2009-10	2010-11	2011-12	2012-13	2013-14
10. Considering the potential for housing support, housing related services and tele care to support people with dementia and their carers.	Coming on stream			Full Implementation	
11. Living well with dementia in care homes	Gearing up	Coming on stream		Full Implementation	
12. Improved end of life care for people with dementia	Gearing up	Coming on stream		Full implementation	
13. An informed and effective workforce for people with dementia	Gearing up		Coming on stream	Full implementation	
14. A joint commissioning strategy for dementia.	Gearing up	Coming on stream	Full Implementation		

Work package Summary

This section provides a high level summary of work packages within the programme, full detail can be seen in later sections of this document.

	Description	Relevant Objective	Resource requirement
n/a	Programme Project Management	n/a	Under review
NDS 1.1	Dementia Awareness Gap Analysis	1	Under review
NDS2.1	GP Clinical Lead	2	Under review
NDS3.1	Dementia information needs analysis	3	Under review
NDS5.1	Memory Café modelling	5	JR/AS/DACVS grant
NDS5.2	Support for 3rd sector services needs analysis	5	Under review
NDS11.1	Care home support officer	11	On hold

Objective 1: Improving public and professional awareness and understanding of dementia.

Public and professional awareness and understanding of dementia to be improved and the stigma associated with it addressed. This should inform individuals of the benefits of timely diagnosis and care, promote the prevention of dementia, and reduce social exclusion and discrimination. It should encourage behaviour change in terms of appropriate help-seeking and help provision.

Overview of approach:

Initially to understand the current level of public and professional awareness and then ask ourselves 'what does good mean'. This shall include review of partners approach and activities with particular input from programme reference groups and the Senior Council for Devon. Once these items have been established, targeted activities can be undertaken to address the gap between the current position and what is defined as good.

Responsible Officer: Jenny Richards

Project Manager/Lead Delivery Officer: Jenny Richards/Paul Giblin

NDS requirement	Devon position	Action required	Lead	Start/end		RAG
- Develop and deliver a general public information campaign	Northcliffe Newspaper campaign & survey	Analyse survey outcomes Use Staff newsletters Steller, Healthy Life; DPT Devon Talk articles	Comms leads	June 09	Jan 10	G
- Inclusion of a strong prevention message that 'what's good for your heart is good for your head'	Not formally linked through public health	Arrange link with public health commissioners – now planned for Jan 10	JR	Jan 10	Ongoing	G
- specific complementary local campaigns	Attendance at Public meetings eg Senior Council; health and care interest groups; Alzheimer's groups etc; newspaper articles; radio interviews	Adopt a more systematic approach	Comms leads/JR/DPT	June 09	Ongoing	A

<p>- Targeted campaigns for other specific groups (eg utilities, public-facing service employees, schools, and cultural and religious organisations)</p>	<p>Devon Care Training highlight current strategies and training available through the DCT website, newsletter, mailshot's and conferences. DCT will also act as an information conduit for Devon County Council to the PVI sector and partner agencies</p> <p>The Learning to Involve Project has been commissioned to support the embedding of a patient/carer centred approach within learning for Health and Social Care staff (including those staff who work with people affected by dementia).</p> <p>No current activity</p>	<p>Use the Provider Engagement Network to improve communications and work alongside Public Communications strategy for Dementia.</p> <p>"In My Shoes" will be developed into a range of team based sessions and training for joint agency OPMH teams is being planned.</p> <p>"Real Lives" – Carer Awareness Following a successful pilot in E. Devon a rollout of this joint agency carer awareness training is planned this year in GP Practices and also initially in localities across N and S Devon. This awareness training will include raising issues for carers of people with dementia.</p> <p>SW Strategy Group issue?</p>	<p>EK</p>	<p>09</p>	<p>ongoing</p>	
----------------------------------------------------------------------------------------------------------------------------------------------------------	--------------------------------------------------------------------------------------------------------------------------------------------------------------------------------------------------------------------------------------------------------------------------------------------------------------------------------------------------------------------------------------------------------------------------------------------------------------------------------------------------------------------------------------	---------------------------------------------------------------------------------------------------------------------------------------------------------------------------------------------------------------------------------------------------------------------------------------------------------------------------------------------------------------------------------------------------------------------------------------------------------------------------------------------------------------------------------------------------------------------------------------------------------------------------------------------------------	-----------	-----------	----------------	--

Objective 2: Good-quality early diagnosis and intervention for all.

All people with dementia to have access to a pathway of care that delivers: a rapid and competent specialist assessment; an accurate diagnosis, sensitively communicated to the person with dementia and their carers; and treatment, care and support provided as needed following diagnosis. The system needs to have the capacity to see all new cases of dementia in the area.

Overview of approach:

The DPT Task Group/PEG will hold responsibility for this outcome and will deliver it through their service redesign programme of work. A needs analysis has been completed (see *Devon and Torbay Integrated Dementia Early Diagnosis and Intervention (EDI) Service (June 2009)* which gives detail of activities to achieve this objective.

Additionally, to support the achievement of this objective, a new post – GP Clinical Lead for dementia – is to be created if adequate funding can be secured

Responsible Officer: Dr David Somerfield

Project Manager/Lead Delivery Officer: Ruth Baker

NDS requirement	Devon position	Action required	Lead	Start/end		RAG
- The commissioning of a good-quality service, available locally, for early diagnosis and intervention in dementia, which has the capacity to assess all new cases occurring in that area.	Memory clinics already operate in some parts of Devon either within clinic setting or via community mental health teams	Agree appropriate model based on local and regional experience aligned to rural/urban environments and clearly linked to primary care.	DPT	06/09	10/09	G
		Identify associated costs and seek pump prime funding (links to DPT service redesign)		10/09	11/09	G
		Implement model County wide linked to a whole system pathway		04/10	03/11	A
	Seeking funding for GP clinical lead for dementia to develop local strategy for engaging local GPs	Advertise post / appoint	JR	06/09	03/11	R
	QOF data available but not accurate	Review accuracy	JR/LR	08/09	ongoing	G

Objective 3: Good-quality information for those with diagnosed dementia and their carers.

Providing people with dementia and their carers with good-quality information on the illness and on the services available both at diagnosis and throughout the course of their care.

Overview of Approach:

The DPT Task Group/PEG will hold responsibility for this outcome and deliver it through their service redesign programme of work.

Responsible Officer: David Somerfield

Project Manager/Lead Delivery Officer: Ruth Baker

NDS requirement	Devon position	Action required	Lead	Start/end		RAG
- A review of existing relevant information sets.	Information Task Group oversee	Undertake audit/review-involve primary care	DPT/Vol sector	04/09	03/10	A
- The development and distribution of good-quality information sets on dementia and services available, of relevance at diagnosis and throughout the course of care.	As above	Ensure consistency across Devon in range of environments inc primary care Audit regularly	All		ongoing	A
- Local tailoring of the service information to make clear local service provision	Dementia Carers Pathway booklet widely available	Agree ongoing funding and accuracy assurance	DDPG/ACS/NHS	10/09	ongoing	G

Objective 4: Enabling easy access to care, support and advice following diagnosis.

A dementia adviser to facilitate easy access to appropriate care, support and advice for those diagnosed with dementia and their carers.

Overview of Approach:

Currently there is no funding for this post. DH are currently accepting bids from local authorities for funding to be demonstrator sites for this model. DCC have not made a bid but await feedback to inform the approach. This is not therefore an immediate priority but will be monitored by the programme board through the responsible officer

Responsible Officer: Jenny Richards

Project Manager/Lead Delivery Officer: Jenny Richards

NDS requirement	Devon position	Action required	Lead	Start/end		RAG
<p>- This is a new role and there will be a need first for the development and generation of demonstrator projects</p> <p>- Following this, commissioning a local dementia adviser to provide a point of contact</p> <p>- Contact with a dementia adviser to be made following diagnosis</p> <p>- Dementia adviser not to duplicate existing 'hands-on' case management or care</p>	<p>Currently elements of this undertaken by DPT staff and voluntary sector (Age Concern – Exeter, TTVS, Torridge)</p>	<p>Consider demonstrator bid (not proceeding to bid)</p>	JR			
	<p>Some carer support worker functions may encompass some of this role</p>	<p>Identify current activities that deliver elements of this and opportunities to enhance existing roles</p>	JR	01/10	31/10	G

Objective 5: Development of structured peer support and learning networks.

The establishment and maintenance of such networks will provide direct local peer support for people with dementia and their carers. It will also enable people with dementia and their carers to take an active role in the development and prioritisation of local services

Overview of Approach:

This objective will be met in the following ways:

- Memory Cafes – review current arrangements and develop sustainable model
- Carers Support – as above
- Carer Education – as above linked to ‘self-care’ programme (NHS)

Responsible Officer: Jenny Richards

Project Manager/Lead Delivery Officer: Jenny Richards in partnership with Alzheimer’s Society; Senior Council; DACVS

NDS requirement	Devon position	Action required	Lead	Start/end		RAG
- Demonstrator sites and evaluation to determine current activity and models of good practice to inform commissioning decisions	Considering demonstrator site status re Memory café network	Response to bidding process to DH (not successful)	JR			
- Development of local peer support and learning networks for people with dementia and their carers that provide practical and emotional support, reduce isolation and promote self-care, while also providing a source of information about local needs to inform commissioning decisions	Memory Cafes: 17 across Devon – variety of models. Report complete	Develop one in each of 29 market & coastal towns Engage stakeholders Rollout model Link to mentoring service	JR	06/09	03/11	G
	Identify carers groups	Map current provision Identify current funding	CC			
	St Johns Ambulance course x8 per year inc dementia advice	Cost education programme for carers (?dementia specific	CC			
- Support to third sector services commissioned by health & social care	Carer Support Workers; Memory Cafes; Carer Education: Funding and support ad hoc					

Objective 6: Improved community personal support services.

Provision of an appropriate range of services to support people with dementia living at home and their carers. Access to flexible and reliable services, ranging from early intervention to specialist home care services, which are responsive to the personal needs and preferences of each individual and take account of their broader family circumstances. Accessible to people living alone or with carers, people who pay for their care privately, through personal budgets, or through local authority-arranged services.

Overview of Approach: This objective shall be delivered through:

- The personalisation programme. The scope of this programme will reflect this objective and will be explicitly referenced within it.
- The redesign of the in-house domiciliary workforce in relation to development of a specialist service for individuals with challenging behaviours. This approach has been adopted by SMG and has been entered onto the PPF programme
- Community Mentoring
- Day care

Responsible Officer: Jennie Stephens

Project Manager/Lead Delivery Officer: Graham Varley/Paul Collinge

NDS requirement	Devon position	Action required	Lead	Start/end	RAG
<p>- Implement <i>Putting People First</i> personalisation changes for people with dementia, utilising the Transforming Social Care Grant</p> <p>- Establish an evidence base for effective specialist services to support people with dementia at home</p> <p>- Commissioners to implement best practice models after thereafter</p>	<p>Refer to Devon action plan for personalisation</p>	<p>Record primary need</p> <p>Record number of people with dementia offered an IB and amount</p> <p>Record outcomes people with dementia choose to achieve</p> <p>Record range of offers of support to secure services (ie Arranging own; support service; ACS brokerage)</p> <p>Commissioning for support – assess whether this needs to be specialist or older people generic service</p> <p>Establish Devon evidence base</p>	<p>Graham Varley</p>		

Objective 7: Implementing the Carers' Strategy for people with dementia.

Family carers are the most important resource available for people with dementia. Active work is needed to ensure that the provisions of the Carers' Strategy are available for carers of people with dementia. Carers have a right to an assessment of their needs and can be supported through an agreed plan to support the important role they play in the care of the person with dementia. This will include good-quality personalised breaks. Action should also be taken to strengthen support for children who are in caring roles, ensuring that their particular needs as children are protected.

Overview of Approach:

This objective shall be delivered through the Carers Programme. The Carers Strategy will be signed off in September 2009 and the scope will include these objectives and measures explicitly referenced within it.

Responsible Officer: Jennie Stephens

Project Manager/Lead Delivery Officer: Clare Cotter

NDS requirement	Devon position	Action required	Lead	Start/end	RAG
<p>- Ensuring that the needs of carers of people with dementia are included as the strategy is implemented</p> <p>- Promoting the development of breaks that benefit people with dementia as well as their carers</p>	Carers Strategy signed off Sept 2009	<p>General review of PAF to take account of people with dementia</p> <p>Analyse current distribution of grant between MH 18-65/65+ functional; and older people</p> <p>Link to personalised budgets</p>	Clare Cotter		

Objective 8: Improved quality of care for people with dementia in general hospitals.

Identifying leadership for dementia in general hospitals, defining the care pathway for dementia there, and the commissioning of specialist liaison older people's mental health teams to work in general hospitals.

Overview of Approach:

Currently identifying acute trust representatives. Consider inclusion of community hospital developments for people with dementia in this standard.

Responsible Officer: Jenny Richards

Project Manager/Lead Delivery Officer: TBA – representatives from Acute Trusts (RD&E; NDHT)

NDS requirement	Devon position	Action required	Lead	Start/end		RAG
- Identification of a senior clinician within the general hospital to take the lead for quality improvement in dementia in the hospital - Development of an explicit care pathway for the management and care of people with dementia in hospital, led by that senior clinician - Gathering & synthesis of existing data on the nature and impacts of specialist liaison OPMH teams to work in general hospitals - Thereafter, the commissioning of above	None at present	Confirm liaison arrangements and agree funding - Agree and cost model aligned to CMHT roles and responsibilities Consider needs in relation to community hospitals Ensure raised awareness amongst staff Consider use of CQUIN to promote and maintain improvement Clarify model and standard within care pathway Encourage providers to review environments using Alzheimer's Society environment guide	JR/GB/EH/NDHT/DPS	09/09	03/10	A
	No defined liaison role			04/10	ongoing	G

Objective 9: Improved intermediate care for people with dementia.

Intermediate care which is accessible to people with dementia and which meets their needs.

Overview of Approach:

This objective shall be delivered through the Intermediate Care Programme. This is in its formative stages and is impacted by external dependencies such as plans to externalise certain care facilities. Once this programme takes shape, the scope will include this objective which will be explicitly referenced within it. This will be carried forward to the implementation plan and the responsible officer shall keep the board informed

Responsible Officer: Jennie Stephens

Project Manager/Lead Delivery Officer: Paul Collinge

NDS requirement	Devon position	Action required	Lead	Start/end		RAG
<p>- The needs of people with dementia to be explicitly included and addressed in the revision of the Dept of Health's 2001 guidance on intermediate care.</p>	<p>2 specialist intermediate care units for OPMH</p> <p>In-house units for dementia currently exclude those with cognitive impairment</p>	<p>Map and understand patterns of usage</p> <p>Link to future plans for development of in-house care homes</p> <p>Ensure clear links between CCT/Intermediate Care and CMHT</p>	<p>Paul Collinge</p>	<p>03/09</p>	<p>ongoing</p>	<p>A</p>

Objective 10: Considering the potential for housing support, housing related services and telecare to support people with dementia and their carers.

The needs of people with dementia and their carers should be included in the development of housing options, assistive technology and telecare. As evidence emerges, commissioners should consider the provision of options to prolong independent living and delay reliance on more intensive services.

Overview of Approach:

Devon has developed an Extra Care Commissioning Strategy which, along with the joint commissioning strategy for dementia, articulate the need for extra care housing to meet the accommodation, care and support needs of people with dementia. However, key issues for Devon in determining the best model to meet these needs include:

- The rural nature of the county
- Integration of people with dementia within schemes (pepper-potting v separate 'wing' v specialist schemes / acceptance of others living in the schemes etc.)
- Design and wider community environment - best practice
- Security of tenure / family carers / end of life care within extra care schemes and links with specialist services

Inc 'Just Checking' pilot

Responsible Officer: Jennie Stephens

Project Manager/Lead Delivery Officer: Alison Golby

NDS requirement	Devon position	Action required	Lead	Start/end	RAG
-----------------	----------------	-----------------	------	-----------	-----

<p>- Monitoring the development of models of housing, including extra care housing, to meet the needs of people with dementia and their carers</p> <p>- Staff working within housing and housing-related services to develop skills needed to provide the best quality care and support for people with dementia in the roles and settings where they work</p> <p>- A watching brief over the emerging evidence base on assistive technology & telecare to support people once effectiveness is proven</p>	<p>56 units of extra care in Devon: Douro Court & Newton Ferrers. None specialise in dementia care.</p> <p>Draft commissioning plan completed for 1400 units</p> <p>Formal L&D approach not established</p> <p>Moving from pilot to mainstream Considering 'Just Checking' model</p>	<p>Finalise extra care commissioning plan using a phased approach; Secure development partners. Tendering process</p> <p>Identify and map need</p> <p>Ensure metrics include identification of people with dementia – numbers & case studies to inform evidence base/good practice</p>	<p>AG</p>	<p>7/09</p> <p>4/09</p>		
----------------------------------------------------------------------------------------------------------------------------------------------------------------------------------------------------------------------------------------------------------------------------------------------------------------------------------------------------------------------------------------------------------------------------------------------------------------------------------------------------------------	--------------------------------------------------------------------------------------------------------------------------------------------------------------------------------------------------------------------------------------------------------------------------------------------------	----------------------------------------------------------------------------------------------------------------------------------------------------------------------------------------------------------------------------------------------------------------------------------------------------	-----------	-------------------------	--	--

Objective 11: Living well with dementia in care homes.

Improved quality of care for people with dementia in care homes through the development of explicit leadership for dementia care within care homes, defining the care pathway there, the commissioning of specialist in-reach services from community mental health teams, and through inspection regimes.

Overview of Approach:

This objective will be achieved through the appointment of 3 posts to support improvements. The remit of these posts shall be explicitly linked to this objective.

Responsible Officer: Jenny Richards/TBA GP Clinical Lead

Project Manager/Lead Delivery Officer: Jenny Richards/TBA GP Clinical Lead

NDS requirement	Devon position	Action required	Lead	Start/end		RAG
<ul style="list-style-type: none"> - Identification of a senior staff member in the care home to take the lead for quality improvement in the care of dementia in the care home - Develop local strategy for the management & care of people with dementia in the care home, led by that senior staff member - Only appropriate use of anti-psychotic medication for people with dementia - The commissioning of specialist in-reach services from community OPMH teams to work in care homes 	Short term – proposal to appoint 3 people to support improvements.	Agree funding	JR	06/09	03/11	R
		Appoint				
		Longer term ensure capacity within CMHT to maintain and support continuous improvement? Service spec design	JR/GB	11/09	03/10	
		Stimulate role of dementia champions in care homes				
		Identify risk factors in relation to homes with specific difficulties				
		Promote use of Alzheimers Society guide on environments				
		GP/Care Home engagement/training	JR			
		As Above – service spec				

Objective 11: Continued						
NDS requirement	Devon position	Action required	Lead	Start/end		RAG
<p>- The specification and commissioning of other in-reach services such as primary care, pharmacy, dentistry, etc</p> <p>- Readily available guidance for care home staff on best practice in dementia care</p>	<p>Managers and assistant managers of care homes are the prime source of readily available guidance for their staff on best practice in dementia care. In 2006, managers and assistant managers of ACS residential homes attended a 3-day course in "Managing Quality Dementia Care", delivered by Dementia Voice.</p> <p>Since March 2007, Mental Capacity Act (MCA) training has been provided for managers and assistant managers of care homes in the statutory and PVI sectors in Devon and Torbay. The MCA is relevant to service users who may have, or who may develop, dementia and who, consequently, may have difficulty in making, or be unable to make, their own decisions. The training has been provided by members of the MCA training pool. The training stresses the need for decision makers to have regard to the MCA Code of Practice.</p>	<p>It has been decided that from April 2009, MCA training, including the Deprivation of Liberty Safeguards (DoLS), will be incorporated in Safeguarding Adults training and be provided by the ACS Safeguarding Adults Team. E-learning packages will be available on Safeguarding Adults, MCA and DoLS.</p>				

Objective 12: Improved end of life care for people with dementia.

People with dementia and their carers to be involved in planning end of life care which recognises the principles outlined in the Dept of Health End of Life Care Strategy. Local work on the End of Life Care Strategy to consider dementia.

Overview of Approach:

This objective shall be delivered through the End of Life Care Programme.

Responsible Officer: Jenny Winslade

Project Manager/Lead Delivery Officer: Lorna Potter

NDS requirement	Devon position	Action required	Lead	Start/end	RAG
<p>- Initiating demonstration projects, piloting and evaluation of models of service provision prior to implementation, given the lack of definitive data in this area</p> <p>- Developing better end of life care for people across care settings which reflects their preferences and makes full use of the planning tools in the Mental Capacity Act</p>	<p>End of Life care workshop to develop approach 25th March 2009</p> <p>In preparation for the MCA coming into force in 2007, briefing sessions on the Act were provided for health and social care staff working in the statutory and PVI sectors in Devon and Torbay. The sessions included the introduction of new forms of Lasting Powers of Attorney, Advanced Decisions and Advanced Statements, which provide service users who have mental capacity with the opportunity to plan for a time when they may lack it, to ensure that their preferences and wishes are reflected in the care provided them.</p>	<p>Awaiting outputs</p> <p>Mental Capacity Act training continued throughout 2008 and is due to end as a discrete activity by the end of March 2009. Thereafter, action has been taken to incorporate it in Safeguarding Adults training.</p> <p>Develop fast track CHC that recognises people with dementia?</p> <p>Liverpool Care pathway training for all relevant staff</p>	LP		

<ul style="list-style-type: none"> - Developing local end of life care pathways for dementia consistent with the Gold Standard framework as identified by the End of Life Care Strategy - Ensuring that palliative care networks, developed as part of the End of Life Care Strategy, support the spread of best practice on end of life care in dementia - Developing better pain relief and nursing support for people with dementia at the end of life 	<p>The training in the Mental Capacity Act, Managing Quality Dementia Care, Dementia Care Awareness, and Dementia Awareness, outlined on the next page, under objective 13, support the spread of best practice on end of life dementia care. All but Managing Quality Dementia Care is already planned to continue in 2009.</p>					
--------------------------------------------------------------------------------------------------------------------------------------------------------------------------------------------------------------------------------------------------------------------------------------------------------------------------------------------------------------------------------------------------------------------------------------------------------------------------------------------------------	----------------------------------------------------------------------------------------------------------------------------------------------------------------------------------------------------------------------------------------------------------------------------------------------------------------------------------	--	--	--	--	--

Objective 13: An informed and effective workforce for people with dementia.

All health and social care staff involved in the care of people who may have dementia to have the necessary skills to provide the best quality of care in the roles and settings where they work. To be achieved by effective basic training and continuous professional and vocational development in dementia.

Overview of Approach:

This objective shall be delivered through workforce development teams who will produce strategy documents followed by implementation plans (joint where appropriate). Progress shall be reported by the Responsible officer.

Responsible Officer: Piers Tetley

Project Manager/Lead Delivery Officer: Katy Kerley

NDS requirement	Devon position	Action required	Lead	Start/end	RAG
<p>- DH workforce strategies to take on board the implications of the dementia strategy</p> <p>- DH to work with representatives of all bodies involved in professional and vocational training and continuing professional development to reach agreement on the core competencies required in dementia care</p> <p>- These bodies to consider how to adapt their current curricula and requirements to include these core competencies in pre- and post-qualification and occupational training</p>	<p>(ACS)Mental Capacity Act training has been provided since March 2007 to health and social care staff working in the statutory and PVI sectors in Devon and Torbay. The Act is relevant to service users who have, or may, a dementia which affects their ability to make decisions.</p> <p>In 2006, managers of ACS residential homes and day centres were provided with "Managing Quality Dementia Care" training. The training was 3 days in duration and was delivered by Dementia Voice.</p> <p>Since 2008, Dementia Care Awareness training has been provided to ACS frontline care staff working in older people's services. The 1-day training is course is delivered by a former ACS manager.</p> <p>Since the end of 2007, dementia awareness training has been included in 4 induction programmes for staff employed in the Raid Equipment and Minor Adaptations Service (REMAS). This training has been provided by the Devon Partnership</p>	<p>Whole system work force strategy required</p> <p>Training strategy to support implementation of Joint Commissioning strategy and NDS</p> <p>From April 2009, Mental Capacity Act Training will cease as a discrete activity and will be incorporated in Safeguarding Adults training.</p> <p>Steps are being taken to involve</p>	<p>Workforce leads via PT with SHA /DH support</p>	<p>ongoing</p>	

	<p>Trust.</p> <p>Currently DCT signpost Safeguarding and MCA training as provided by DCC. DCT have provided ½ and 1 day courses in Dementia Awareness and Communication in the past as well as Dementia & Learning Disability. Currently DCT are planning a range of courses to raise awareness and also to help staff with specific areas around Dementia. These include (but not an exhaustive list):</p> <ul style="list-style-type: none"> • Dementia Awareness/ Understanding Dementia • Dementia & Communication • Dementia & Depression • Dementia & Learning Disability • SOFI Monitoring Tool (CSCI Assessment Tool) • Train the Trainer; Dementia • Sexuality & Dementia • Person Centred Approaches for Dementia Care • Working with Life Story • Dementia Care Mapping • Working with Unusual Behaviour • Diet & Nutrition • Diversity • Developing Positive Relationships with Family & Carers • Behaviour that Challenges • Culture & Dementia • Group Activities • Managing Services for People with Dementia • Dementia & Medication <p>These are provided to DCT Members at no cost and at various locations around the County. DCT Estimates 129 of 205 members have some provision or need of Dementia Training for their staff. The breakdown in the</p>	<p>more ACS managers in the delivery of this training to ensure its accessibility for all ACS frontline care staff.</p> <p>We intend to continue to include dementia awareness training in any further induction programmes for REMAS assessors.</p> <p>DCT are currently putting a programme of courses based on these topics based on DCT members needs. This programme is scheduled to start in May and will run through to March 2010</p>				
--	---------------------------------------------------------------------------------------------------------------------------------------------------------------------------------------------------------------------------------------------------------------------------------------------------------------------------------------------------------------------------------------------------------------------------------------------------------------------------------------------------------------------------------------------------------------------------------------------------------------------------------------------------------------------------------------------------------------------------------------------------------------------------------------------------------------------------------------------------------------------------------------------------------------------------------------------------------------------------------------------------------------------------------------------------------------------------------------------------------------------------------------------------------------------------------------------------------------------------------------------------------------------------------------------------------------------------------------------------------------------------------------------------------------------------------------------------------------------------------------------------	-----------------------------------------------------------------------------------------------------------------------------------------------------------------------------------------------------------------------------------------------------------------------------------------------------------------------------------------------------------------------------------------------------------------------------------------------	--	--	--	--

	<p>County, based on CSCI reports is:</p> <p>29 Dementia Care Homes with nursing provision. These have 1256 places. Of these the CSCI Inspection ratings are:</p> <p>3 star – 4 2 star – 16 1 star – 3 0 star – 3 unrated – 3 (this normally means they have yet to be inspected under this scoring system). None have a suspended rating.</p> <p>119 Dementia Care homes without nursing provision: These have 3005 places. Of these the CSCI Inspection ratings are:</p> <p>3 star – 20 2 star – 68 1 star – 21 0 star – 2 unrated – 8 (this normally means they have yet to be inspected under this scoring system). None have a suspended rating.</p> <p>Using the NMDS reporting, the total of 148 Dementia Care Homes would employ and average of 33 staff per establishment. This would indicate approximately 4,900 staff would need training in the dementia area.</p> <p>(PCT)All staff receives basic Safeguarding Adults Awareness training on Induction and Mandatory Sessions. Staff can access the specialist care of older people module provided by the University of Plymouth, 3 people attended in 08/09. We have provided bespoke Dementia training sessions to 45 staff.</p>					
--	-------------------------------------------------------------------------------------------------------------------------------------------------------------------------------------------------------------------------------------------------------------------------------------------------------------------------------------------------------------------------------------------------------------------------------------------------------------------------------------------------------------------------------------------------------------------------------------------------------------------------------------------------------------------------------------------------------------------------------------------------------------------------------------------------------------------------------------------------------------------------------------------------------------------------------------------------------------------------------------------------------------------------------------------------------------------------------------------------------------------------------------------------------------------------------------------------------------------------------------------------------------------	--	--	--	--	--

	<p>Staff can access training delivered by RD&E and have attended the following sessions: Falls awareness workshop- number of attendees 2 Parkinson's Awareness- number of attendees 34 Mentor Preparation workshop- number of attendees 8 Staff have been able to access training delivered by SDHFT and have attended the following sessions: Dementia- number of attendees 4 Falls Training- number of attendees 4 Staff have been able to attend Mental Capacity Act training sessions. This will now be an E-learning package which all staff can access. For 09/10 there are two new University of Plymouth developments available to Devon PCT staff. The first one is end of life study days and the second is management of persons with dementia. This is a partnership model run by SDHFT on behalf of the University.</p>					
--	----------------------------------------------------------------------------------------------------------------------------------------------------------------------------------------------------------------------------------------------------------------------------------------------------------------------------------------------------------------------------------------------------------------------------------------------------------------------------------------------------------------------------------------------------------------------------------------------------------------------------------------------------------------------------------------------------------------------------------------------------------------------------------------------------------------------------------------------------------------------------------	--	--	--	--	--

Objective 14: A joint commissioning strategy for dementia.

Local commissioning and planning mechanisms to be established to determine the services needed for people with dementia and their carers, and how best to meet these needs. These should be informed by the World Class Commissioning guidance to support the Strategy and set out at Annex 1.

NDS requirement	Devon position	Action required	Lead	Start/end		RAG
<p>- A joint commissioning strategy based on the JSNA; specifying the outcomes required and developed in consultation with people with dementia and their carers.</p> <p>They will need:</p> <ul style="list-style-type: none"> - a community focus, linking into LAA and the development of sustainable communities - an individual focus, drawing on the use of personal budgets and the commissioning of self-directed support - informed by WCC specific guidance for dementia 	<p>Final version agreed and signed off</p>		<p>JR</p>			<p>G</p>

Objective 15: Improved assessment and regulation of health and care services and of how systems are working for people with dementia and their carers.

Inspection regimes for care homes and other services that better assure the quality of dementia care provided.

NDS requirement	Devon position	Action required	Lead	Start/end		RAG
<ul style="list-style-type: none"> - Care Quality Commission (CQC) operational from April 2009 with crucial role to drive up standards - CQC will use the Short Observation Framework for Inspection (SOFI) to have a structured way of observing people's experiences - Inspectorates to include an assessment of the quality of care that people with dementia experience 						

Objective 16: A clear picture of research evidence and needs.

Evidence to be available on the existing research base on dementia in the UK and the gaps that need to be filled.

NDS requirement	Devon position	Action required	Lead	Start/end		RAG
- The Medical Research Council (MRC) with DH to convene a summit of parties interested in dementia research						

Objective 17: Effective national and regional support for implementation of the Strategy.

Appropriate national and regional support to be available to advise and assist local implementation of the Strategy. Good-quality information to be available on the development of dementia services, including information from evaluations and demonstrator sites.

NDS requirement	Devon position	Action required	Lead	Start/end		RAG
<ul style="list-style-type: none"> - DH will provide support for all those involved in implementing the strategy locally to ensure its delivery, particularly for those areas where services are less developed - Localities will need help with 'getting started', particularly if little attention has previously been given strategically to the needs of people with dementia - Regional support teams will be convened to support local implementation 						

Objective 17: Continued

NDS requirement	Devon position	Action required	Lead	Start/end		RAG
<ul style="list-style-type: none"> - Information will be gathered on an annual basis by DH from both NHS and social services to review the extent of current services for people with dementia and their carers, and to track these over time to monitor progress on implementing the NDS - A national baseline measurement of services will be established - Specifically commissioned research, evaluations and data from demonstrator sites will support the implementation of the Strategy 						